

Nordfab In-line Spark Trap 3255

ID In.	W (nom. in.)	H (nom. in.)	Std Weight (lb. Galv)	Galvanized Steel			304SS			Our Pressure Loss Test Results	
				22ga	20ga	18ga	22ga	20ga	18ga	ID In.	Airflow at 3000 FPM prior to Spark Trap (w.g.)
4	18	7	6	Std	Optional		Std		4	-0.85	
5	20	9	7						5	-0.85	
6	20	10	8						6	-0.90	
7	22	12	11			Optional			7	-1.00	
8	22	13	13						8	-1.10	
9	24	15	15						9	-1.10	
10	24	16	16						10	-1.20	
11	26	18	19						12	-1.35	
12	26	19	21						14	-1.45	
13	28	21	23			Std			16	-1.20	
14	28	22	26						18	-1.20	
16	30	25	33						20	-1.25	
18	32	28	47				22	-1.20			
20	34	31	58				24	-1.25			
22	38	35	72								
24	40	38	87								



Not an explosion isolation device*

IMPORTANT: Spark trap must be mounted in a horizontal position.

The Nordfab In-line Spark Trap is a simple, low-cost tool that can reduce incidents of fire events, reducing costs and disruption and improving safety. System redundancy and complementary measures should be applied. It is not a primary safety device and does not replace spark detection or explosion isolation devices.

Duct distance recommended

At least ten diameters from cyclone / collector

Airflow velocity

1500 - 5000 fpm (7.62m/sec - 25.4m/sec)

Construction

Collars: Collars have a laser welded longitudinal seam.

Ends: Standard QF end can be changed to Raw ID (RAWID), Raw OD (RAWOD), No Fitting (NF), Hose Adapter (RAWFLEX), Flat Flange (FFL), Angle Flange (ANGFL), or Van Stone (VANSTONE).

Notes: The exterior is available in optional materials, as shown above, but the internal components must remain standard.

Spark Traps, sizes 4" - 14", are sold only as a complete unit, which includes two sections and a clamp attaching the sections. Diameter of both ends must be the same measurement (i.e. if diameter of airflow side is 6", diameter of downstream side must also be 6".)

Spark Traps, sizes 16" - 24", are sold only as a complete unit, which includes two sections attached via standing seam. These sizes cannot be disassembled.

Clamps are not available in 316SS

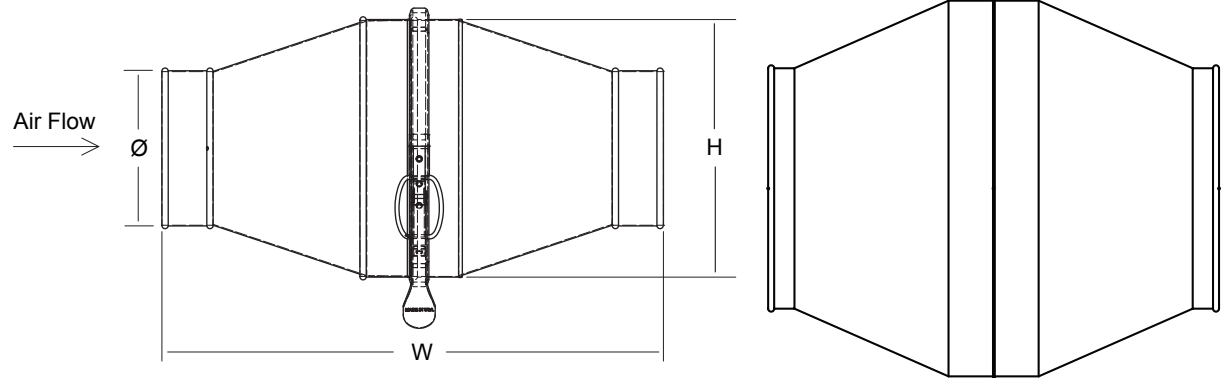

Drawing above left is illustrative of construction of Spark Traps in sizes 4"- 14".

Drawing above right is illustrative of construction of Spark Traps in sizes 16" - 24".

Nordfab In-line Spark Trap 3255

Temperature Rating of Product Components

° F	Spark Trap		QF Clamp Seal*		Sealants			
600°		Optional - 304SS		Optional - Expanded PTFE	3M Scotch Seal Metal Sealant 2084	Optional - Rock River Silicone Sealant	Optional - Red Devil HVAC/R High Temperature Silicone Sealant	Optional - Epoxy is 3M DP 125 Gray Sealant
500°								
390°	Galvanized Steel			Nitrile				
158° (intermittent to 194°)								

Additional Notes

At temperatures ranging between 390° F and 480° F, the zinc-iron alloy layers in galvanized steel will continue to provide a high level of protection from corrosion. However, there may be some peeling, changes in mechanical properties, and reduction in the corrosion protection. Recommended max. service temperature is 390° F.

Rock River Silicone Sealant and Red Devil HVAC/R High Temperature Silicone Sealant are not paintable

304SS:
• bluing may occur at 800° F and above

316SS clamps not available

*Each In-line Spark Trap, sizes 4" - 14", includes a QF clamp to attach the two sections together. If your application requires materials rated for temperatures consistently higher than 158°F, please specify the optional ePTFE seal available for the clamp, which allows application up to 600°F. Larger Spark Traps are attached via standing seam without QF Clamps.

Compliance / Rating of Product Components

Product	Material	Compliance / Rating
In-line Spark Trap	Galvanized	ASTM A653 with a G-90 rating
	304SS	Finish meets ASTM A240
Clamp Seals (Not applicable sizes 16" - 24")	Nitrile	ASTM D 1056
	100% ePTFE	Not degraded by any common chemicals (0 - 14 pH range) FOR INDUSTRIAL USE ONLY. Not for use in food, drug, cosmetic or medical device manufacturing, processing, or packaging operations. Compressibility 52% (ASTM F-36), Sealability: .03 ml/hr (ASTM F-37-B) 30 psig/2 bar-air.
3M Scotch Seal Metal Sealant 2084	Acetone blend	AAMA Specification 801.1
Rock River Sealant	100% Silicone	ASTM C920 Class 25, TT-S-00230C Class A and TT-S-001543A, FDA No 421 CFR 117.2600, conforms to FDA requirements
Red Devil HVAC/R High Temperature Sealant	Silicone	ASTM C920 Class 25, TT-S-00230C Class A and TT-S-001543A, CEBTP 432.6 140-2, Mil Spec 46106A, CGSB 19C9-9B, DIN 18540 Part 2, OREX 150031-2